

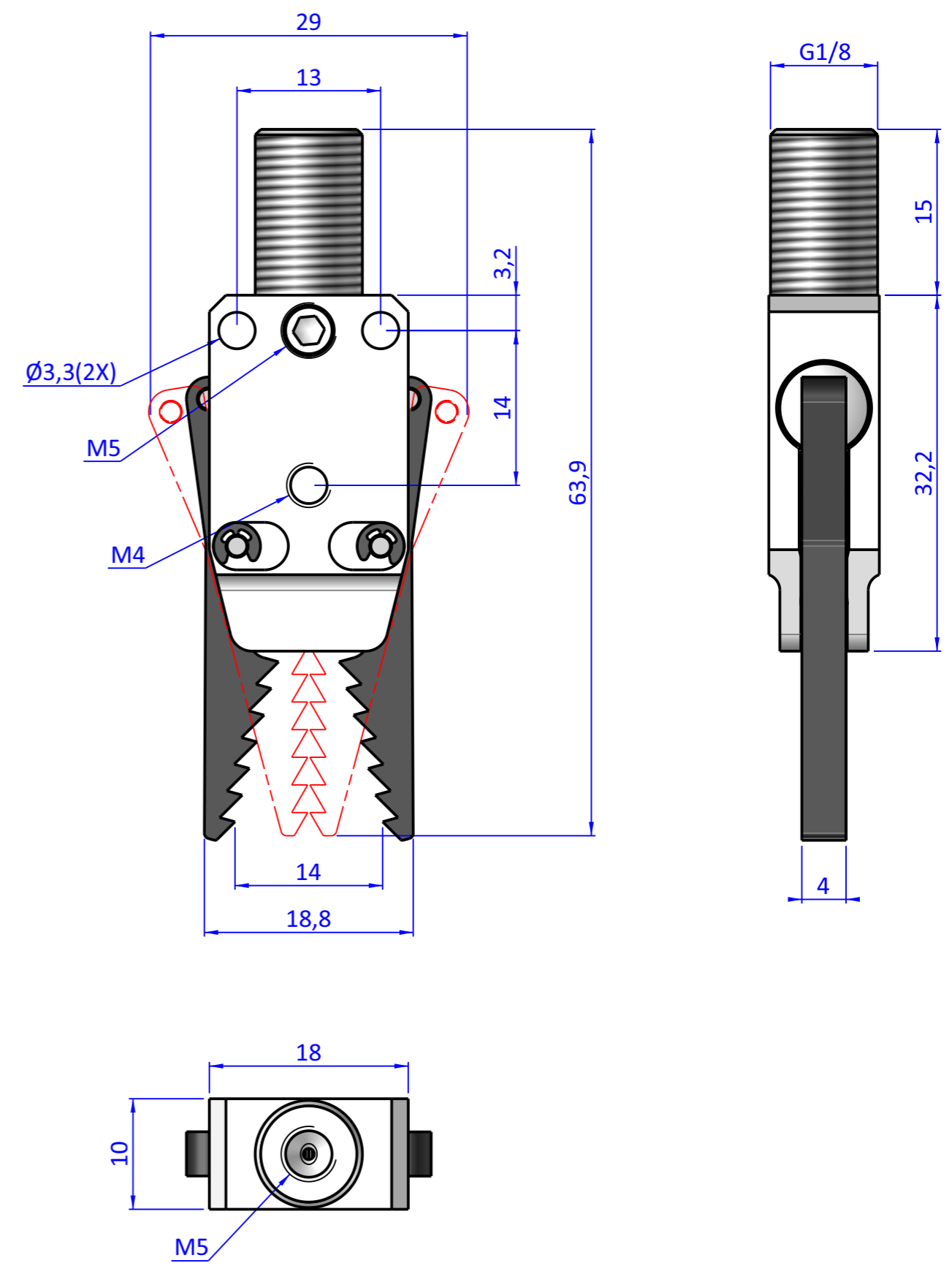

THE PROPERTY OF THE DRAWING IS ESTABLISHED BY LAW. IT IS FORBIDDEN TO PRODUCE OR SHOW IT TO THIRD PART. WITHOUT A WRITTEN AGREEMENT.

| Item | Name           | Qty. |
|------|----------------|------|
| 1    | A.ELA.RA1.5    | 2    |
| 2    | GR.5X4         | 1    |
| 3    | GZA.10.08.1.18 | 1    |
| 4    | GZA.10.08.2.OR | 2    |
| 6    | GZA.10.08.9    | 2    |
| 5    | GZA.10.08.19   | 2    |
| 7    | M.MP13X3.5D.5  | 1    |
| 8    | SP.2x10SS      | 2    |

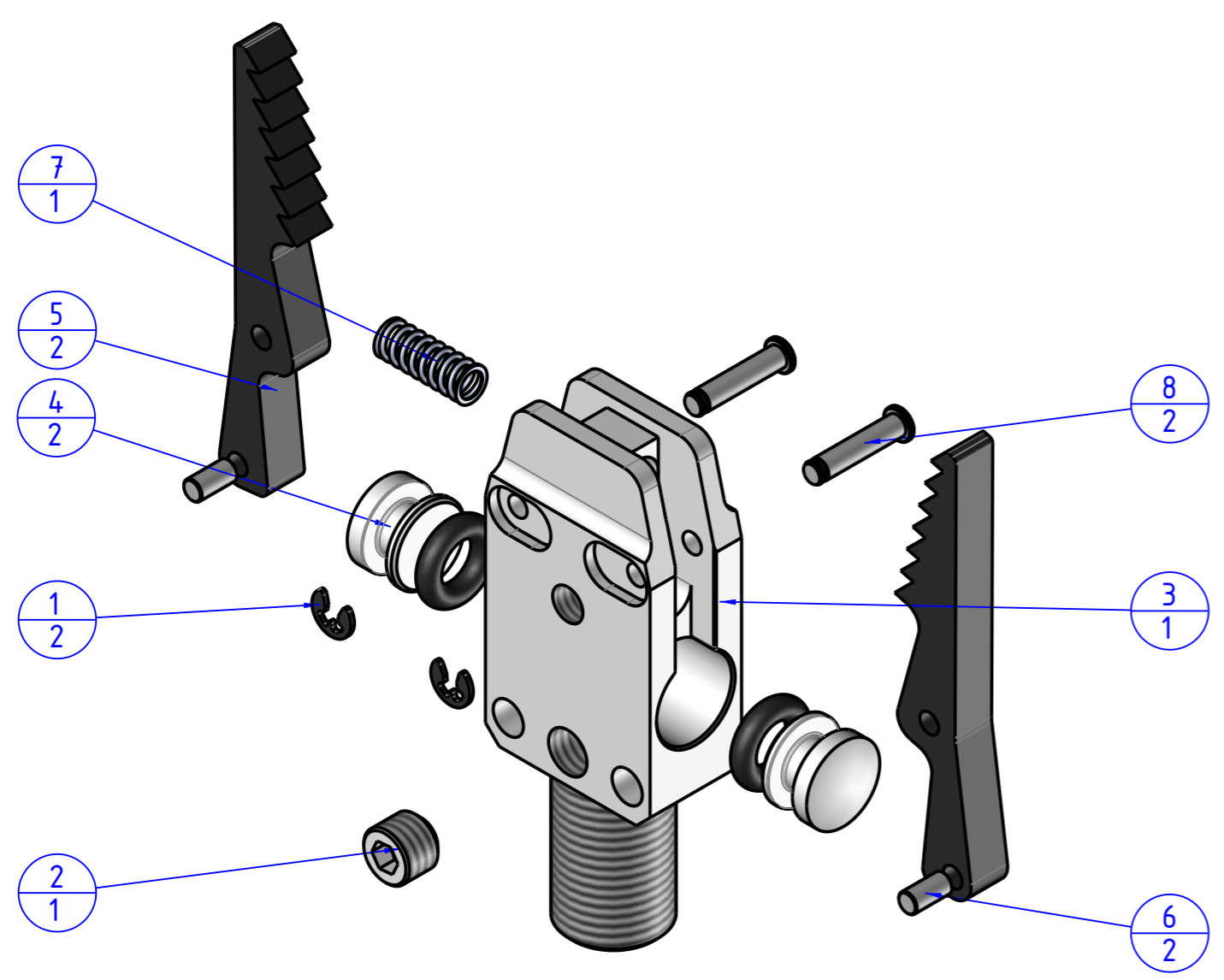

Format A3  
UNI 936-76

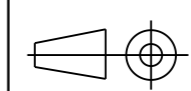
|  |  |   |  |                                 |
|--|--|---|--|---------------------------------|
| <br><b>FPS</b><br>FPSERVICES AUTOMATION |  |  | DESIGNED FROM<br><b>FPS Automation</b> | REVIEW<br><b>A</b>              |
| GENERAL TOLERANCE<br>UNI - ISO 2768<br>CLASSE f  |  | DESCRIPTION<br><b>CA.GZA.10.08.18</b>   |  | DATE<br><b>07/04/2026</b>       |
|  |  | WEIGHT<br><b>0,020kg</b>  |  | CODE<br><b>CA.GZA.10.08.101</b> |